

The SABRE-300 is the latest cutting-edge machine introduced into the market-leading Record Power SABRE series of bandsaws. Designed and developed with the keen hobbyist woodworker in mind, the SABRE-300 embodies the next step in the evolution of our flagship bandsaw range, offering a high-quality and extremely versatile machine, at a size suitable for most workshops. With a multitude of innovative features, substantial power and capacity, the SABRE-300 is the ideal machine for handling a wide variety of tasks, ranging from intricate small-scale items to larger, heavier workpieces, making it the ultimate multi-purpose bandsaw.

Key Features and Benefits

Rip Fence Micro-Adjustment

The advantageous rip fence micro-adjustment feature enables extremely accurate positioning, helping users to achieve the desired position quickly and easily.

Premium-Grade Sliding Block Blade Guides

The premium-grade sliding block blade guides provide extensive blade support, which helps to minimise vibration and enhances both stability and control. The blade guides are made from premium O1 tool steel, which has been selected for its exceptional ability to dissipate heat far more efficiently than ceramic alternatives. Adjustment of the blade guides is completely tool-free and can be carried out quickly and easily, using the accurate adjustment and locking handles.

Dust Extraction Advancements

The SABRE-300 takes harmful wood dust protection to the next level, with the combination of side and rear dust extraction ports. The rear dust port features a CamVac bayonet fitting, allowing direct connectivity with the Record Power range of CamVac high-filtration dust extractors. The side dust port seamlessly pairs with the Record Power 2.5" flexible hose, streamlining the dust extraction setup. A removable dust cap situated within the lower cabinet over the blade, further reduces airflow leakage, increasing extraction efficiency.



**Rip Fence
Micro-Adjustment**



**Premium-Grade
Blade Guides**

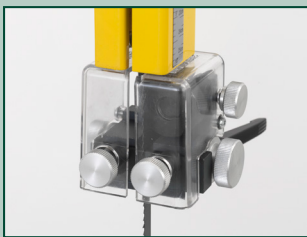

**Dust Extraction
Advancements**



Specifications

Maximum Depth of Cut: 254 mm	Blade Length: 95 1/4" / 2420 mm
Throat Depth: 292 mm	Blade Width Capacity: 1/4-3/4" / 6-19 mm
Table Size: 480 x 400 mm	Blade Speed: 500 and 1000 M / minute
Table Height from Floor: 930 mm	Extraction Port Diameters: 100 mm / 4"
Table Tilt: -6 to 45°	and 63 mm / 2 1/2"
Motor input P1: 1.5 kW	Weight: 89 kg
Motor output P2: 1.1 kW	Size: H1724 x W791 x D670 mm

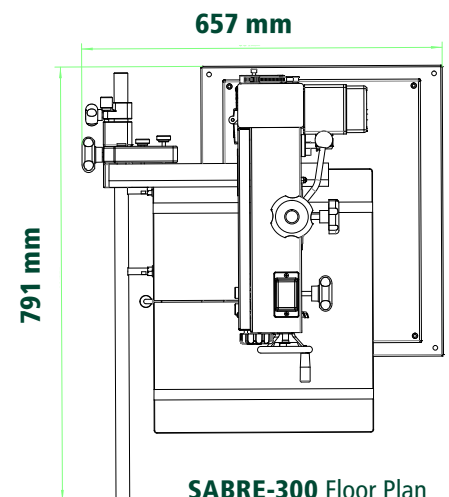

Additional Features and Benefits

Heavy-Duty Balanced Cast Iron Band Wheels

Dynamically balanced and heavy, the cast wheels provide a smooth flywheel effect during use, contributing to the production of power and torque.

Double-Sided Fence Mount

The unique fence mount design allows the fence to be quickly placed to the right-hand side of the blade, with the fence extrusion secured on the opposite side of the mount.

Cam-Action Blade Tension Adjustment

Release and re-apply blade tension instantly using the cam-action handle. This makes changing blade simple and fast and if the new blade is the same as the old, the correct tension can be instantly re-applied on fitment.

Heavy-Duty Trunnion

Solid double trunnion table mount for rigid table support featuring one-handed rack and pinion table tilt for ease of use and accuracy.

Integral Cabinet Base

The cabinet provides useful storage space for tools and timber.

Cam-Action Fence Adjustment and Micro-Adjustment

The cam-action fence adjustment and innovative fine adjustment allows the fence to be positioned with extreme accuracy.

Useful Height Guide

The blade guard features a scale to show the cutting height, an ideal reference for accurately setting the guides to the required position.

Table Levelling Pin

Perfect alignment of the table is ensured with the simple-but-effective levelling pin.

Rack and Pinion Blade Guide Adjustment

The blade guides move on a sturdy rack and pinion system which can be locked in place to provide a fixed rigid repeatable location for ease-of-use.

Upper and Lower Inspection Windows for Easy Blade Tracking

The inspection windows allow the blade to be seen on the wheel from the side, making blade tracking much easier.

Adjustable Table Insert

The table features two essential levelling screws to raise or lower the table insert for a smooth feed over the cast iron table.

High-Quality Switch System

Uses a high-quality contactor for extended durability and longevity.

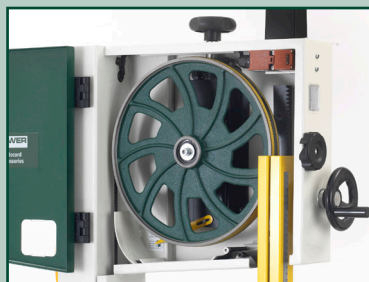

Optional Accessories

BB9514-3PACK Pack of 3 Blades

68051 Heavy Duty Cast Iron Mitre Fence

80004 Resaw Bar

67052 Table Extension 545 x 300 mm

68052 Standard Mitre Fence

69103 Pedal Wheel Kit

SABRE-300 RRP
£999.99 / €1199.95