

# X-LOCK

NOUL STANDARD MONDIAL  
PENTRU  
POLIZOARE UNGHIULARE

# Un X. Care face diferența.

## X-LOCK – noul sistem rapid de înlocuire fără cheie al accesoriilor



Ciocane rotopercutoare mici

1976



Prindere T



Sistem SDS pentru ferăstraie verticale

2000



Polizoare unghiulare

2019

Ciocane rotopercutoare mari



Multi functionale oscilante



# Cea mai modernă modalitate de montare rapidă a accesoriilor

## Sistem complet polizor unghiular - accesorii

# XLOCK



ACCESORII cu  
interfață X-LOCK

POLIZOR UNGHIALAR  
cu interfață X-LOCK

# Nou. De la Bosch!

## Sistemul X-LOCK



### Polizoare unghiulare X-LOCK

Denumire	GWX
Tipuri de baza	8 cu cablu (etapa 1) 2 cu acumulator (etapa 2)
Gama de putere	900 – 1.900 W
Voltaj polizoare cu acumulator/ Putere echivalenta (comparativ cu sculele cu cablu)	18V / 1.000 - 1.500 W
Diametrul discului [mm]	115 / 125



### Segment accesorii Bosch X-LOCK

### Nr. coduri

Discuri abrazive	19
Discuri diamantate	15
Carote diamantate (incl. freza fasonare)	25
Disc taiere carburi metalice Multi Wheel	2
Disc 3 in 1	16
Fibrodiscuri	36
Talere pt. fibrodiscuri / clame sprijin	10 / 1
Perii	9

# Avantajele principale ale utilizatorului – Vedere de ansamblu

## Cea mai comodă metodă de înlocuire a accesoriilor.

### Cel mai comod



- Fără componente care pot fi pierdute
- Fără cheie sau altă unealtă suplimentară
- Montare foarte ușoară a accesoriilor, cu o simplă apăsare ușoară

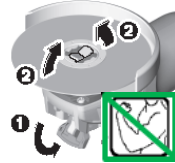

### Fixare sigură a accesoriilor



- Cu răspuns activ (click and feel) când accesoriul este montat și fixat
- Fără posibilitate de montare greșită



### Productivitate crescută



- Înlocuire până la de 5x mai rapidă a accesoriilor, datorită eliminării operațiilor intermediare
- Polizare mai eficientă a suprafețelor plane (mai puține urme pe suprafața polizată)
- Fără piulița de fixare a discului



De 5 x mai repede



- Necesitate scăzută de revenire pe suprafața polizată
- Utilizare crescută a discului

# XLOCK

### Sortiment larg de polizoare & accesorii



- Pentru majoritatea aplicațiilor
- Noile accesorii sunt compatibile cu cele non X-LOCK (cu 3 excepții)



# Solutia moderna pentru schimbarea discului

## Cea mai comodă metodă de inlocuire a accesoriilor

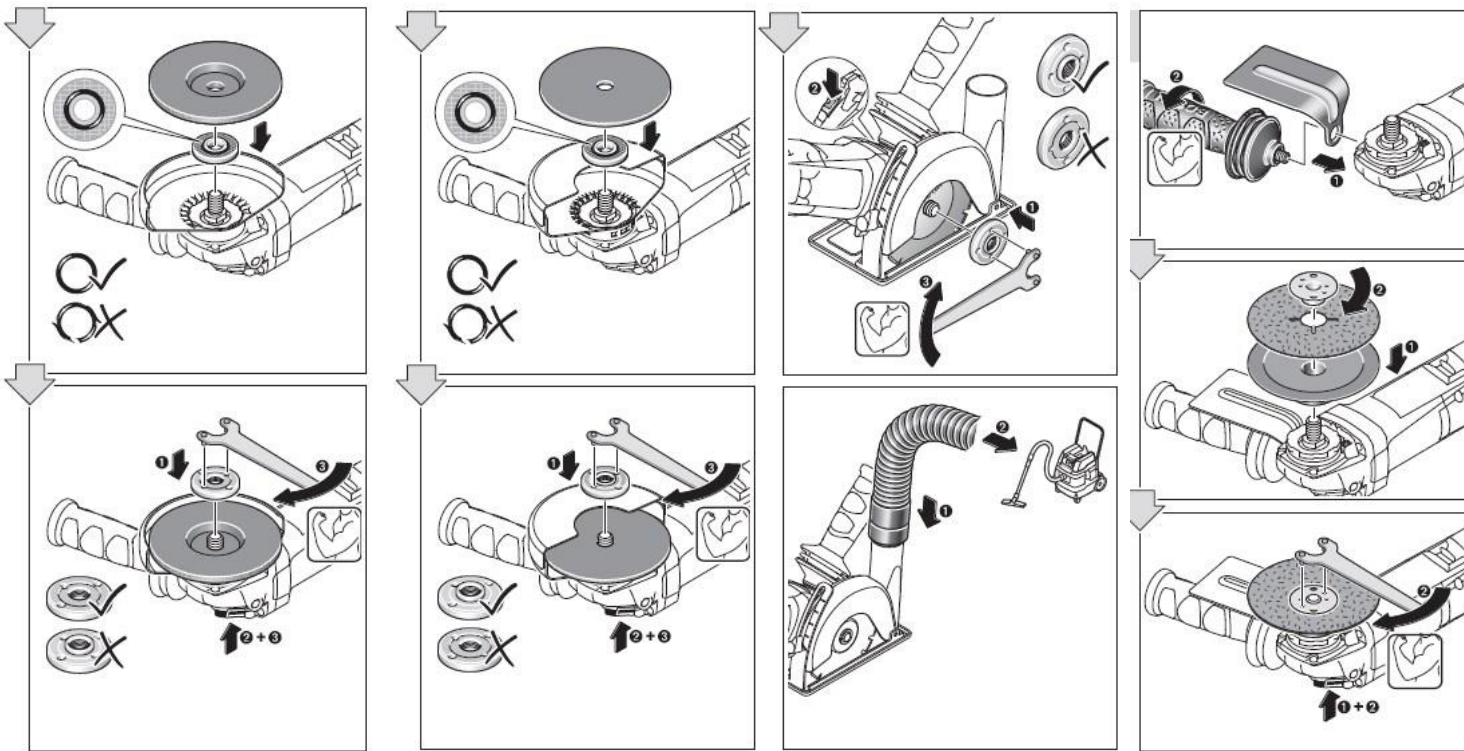

- ✗ Piese ce pot fi pierdute
- ✗ Nevoie de cheie
- ✗ Consuma timp
- ✗ Complicat cu piulite si flanse
- ✗ Este incomod pentru manevrare cu manusi

Extras din manualul de utilizare

# Comod si rapid

Fara piese care se pot pierde sau echipamente suplimentare de montare necesare

## Standard



► Piese care se pot pierde

## XLOCK



► FARA piese care se pot pierde

# Comod si rapid

## Cel mai comod sistem datorita solutiei fara cheie

### Standard



► Cheie aditionala necesara

### XLOCK



► Nu este nevoie de cheie



# Comod si rapid

## Cel mai comod sistem datorita solutiei fara cheie

### Standard



► Cheie aditionala necesara

### XLOCK



► Nu este nevoie de cheie

# Avantajele principale ale utilizatorului – Sortiment cuprinzător

## Sortiment mare de polizoare și accesorii care acoperă o varietate foarte mare de aplicații

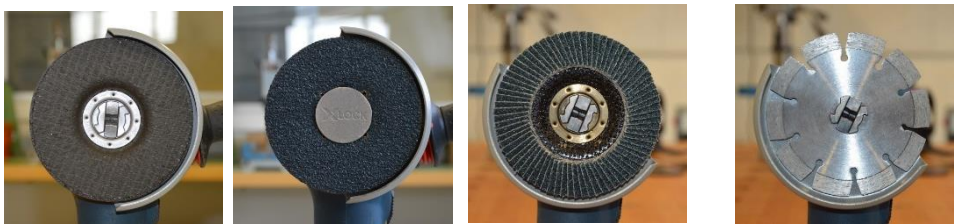

Cu acumulator  
-  
Meseriași / Lăcătuși /  
Constructori

Cu parghie pornire  
-  
Industria /  
Construcții

Putere mare  
-  
Industria

Circumferință mică  
-  
Toți utilizatorii

Tăiere / Polizare / Periere  
  
Metal

Tăiere,  
Găurire  
  
Beton /  
Piatră /  
Plăci  
ceramice

Tăiere  
  
Plastic/  
Lemn cu  
cuie /  
Gipscarton

# Grupuri tinta & utilizari

## Prezentare generala

### Mesteri

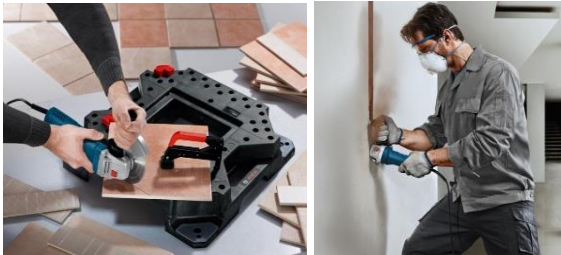

- Taiere/slefuire: 90%/10%

#### Utilizari

- Taiere placi
- Taiere caramida
- Taiere metal
- Indepartare surplus sudura

### Confectii metalice / Constructii



- Taiere/slefuire: 50%/50% (metal)
- Taiere/slefuire: 95%/5% (constructii)

#### Utilizari

- Taiere tevi
- Indepartare surplus sudura
- Pregatire pentru sudura
- Debavurare/ Indepartarea ruginii
- Taiere beton
- Taiere armaturi metalice

### Industrie metalurgica



- Taiere/Slefuire: 20%/80%

#### Utilizari

- Taiere placi otel
- Indepartare surplus sudura
- Pregatire pentru sudura
- Debavurare/ Indepartarea ruginii

# Avantajele principale ale utilizatorului – Compatibilitate

## Aproape toate accesoriile X-LOCK sunt compatibile cu polizoarele unghiulare standard.

Polizor unghiular standard



<b>XLOCK</b>	✓
M14/Ø 22,23	✓

Polizor unghiular X-LOCK



100% compatibile\* ✓

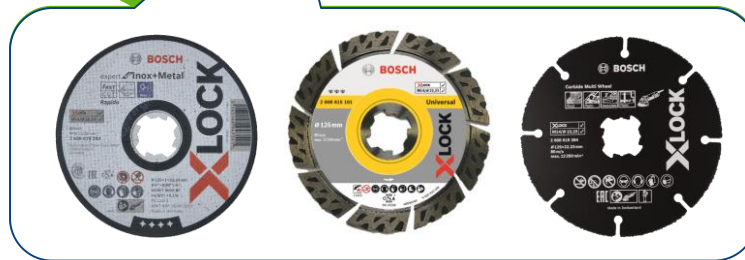

\*cu excepția carotelor diamantate, perilor și talerelor de șlefuire

# Denumire produs

Noul mod de notare al polizoarelor unghiulare X-Lock pentru o diferențiere foarte clară



GWS → **GWX**  
**X**LOCK



**1. Modificare notare** (grup litere din finalul denumirii)  
CIE → S

**2. Menținere notare generică a polizoarelor**  
GWS 1000 → GW**X** 10-125





Exemple:

GWS 15-125 CIEP → GWX 15-125 PS

GWS 17-125 CI → GWX 17-125

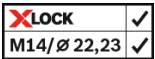
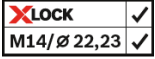
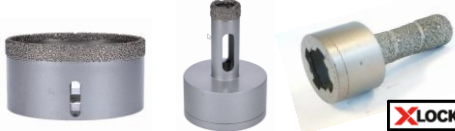

# Vedere de anamblu - Accesorii

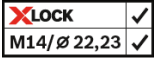
## Gamă accesorii (1/2)

Segment	Numar articole <b>BOSCH</b>
Discuri abrazive  	19
Discuri diamantate  	15
Carote diamantate  	25
Perii  	9
Discuri Multi Material  	2

# Vedere de anamblu - Accesorii

## Gamă accesorii (2/2)

Segment	Numar articole <b>BOSCH</b>
Fibrodiscuri Talere pentru fibrodiscuri 	36 fibrodiscuri 6 talere
Discuri lamelare 	16
Pâsle & talere 	8 pâsle 2 talere
<b>Total articole</b>	<b>138</b>